

# L2C STRADEASY®

Avec fond



D 400

CHAMBRES  
SOUS CHAUSSÉE  
TÉLÉCOMMUNICATIONS

Type L

- L1C
- L1CR
- S L2C**
- L2CR
- L3C
- L3CR
- L5C

Type J

- J2C

Type K

- K1C
- K1CR
- K2C
- K2CR
- K3C
- K3CR

Type M

- M1C
- M1CR
- M3C
- M3CR

Type P

- P1C
- P1CR
- P2C
- P2CR

MISE EN  
OEUVRE  
CCTP



P 98-050-1

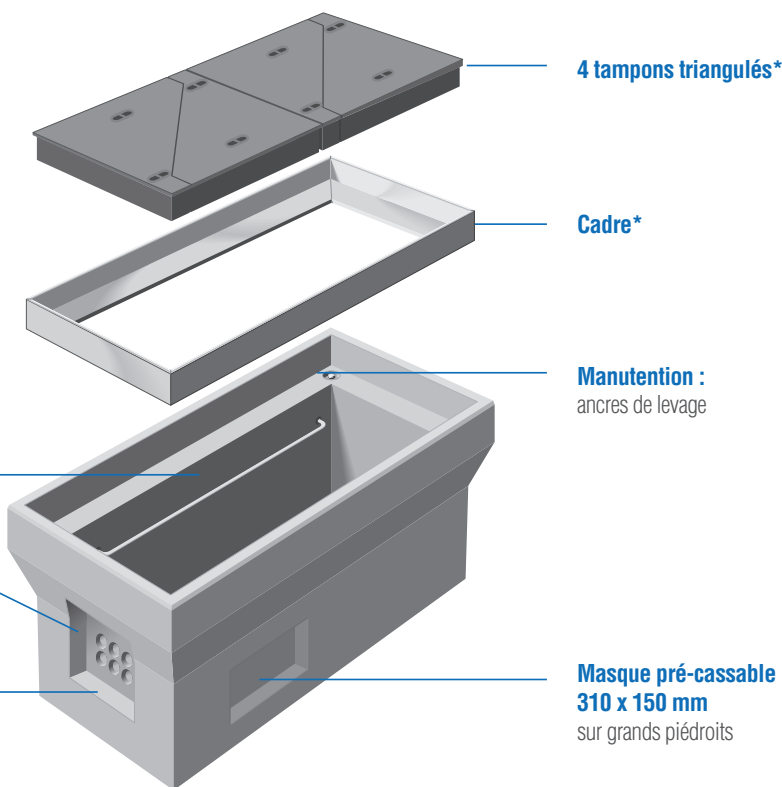

\*Cadres et tampons vendus séparément. Cadre scellé en option.

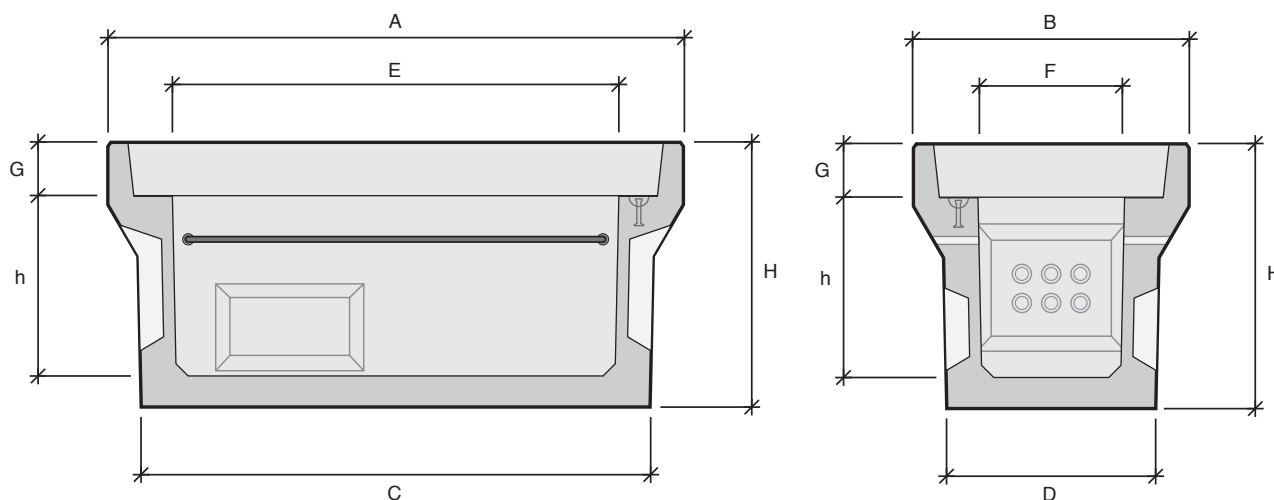

| Désignation | Référence     | Usines    | A<br>Longueur<br>(mm) | B<br>Largeur<br>(mm) | C<br>Longueur<br>radier<br>(mm) | D<br>Largeur<br>radier<br>(mm) | E<br>Longueur<br>intérieure<br>(mm) | F<br>Largeur<br>inférieure<br>(mm) | H<br>Hauteur<br>totale<br>(mm) | h<br>Hauteur<br>utile<br>(mm) | G<br>Hauteur<br>feuillure<br>(mm) | Poids (kg) | Manutention      |
|-------------|---------------|-----------|-----------------------|----------------------|---------------------------------|--------------------------------|-------------------------------------|------------------------------------|--------------------------------|-------------------------------|-----------------------------------|------------|------------------|
| <b>L2C</b>  | <b>110019</b> | <b>EB</b> | 1495                  | 715                  | 1320                            | 550                            | 1160                                | 380                                | 680                            | 460                           | 140                               | 560        | 2 ancrés de 1,3T |
|             |               | <b>MX</b> | 1490                  | 715                  | 1305                            | 530                            | 1155                                | 375                                | 680                            | 460                           | 140                               | 560        | 2 ancrés de 1,3T |