

L3CR STRADEASY®

À radier à reconstituer



D 400



P 98-050-1

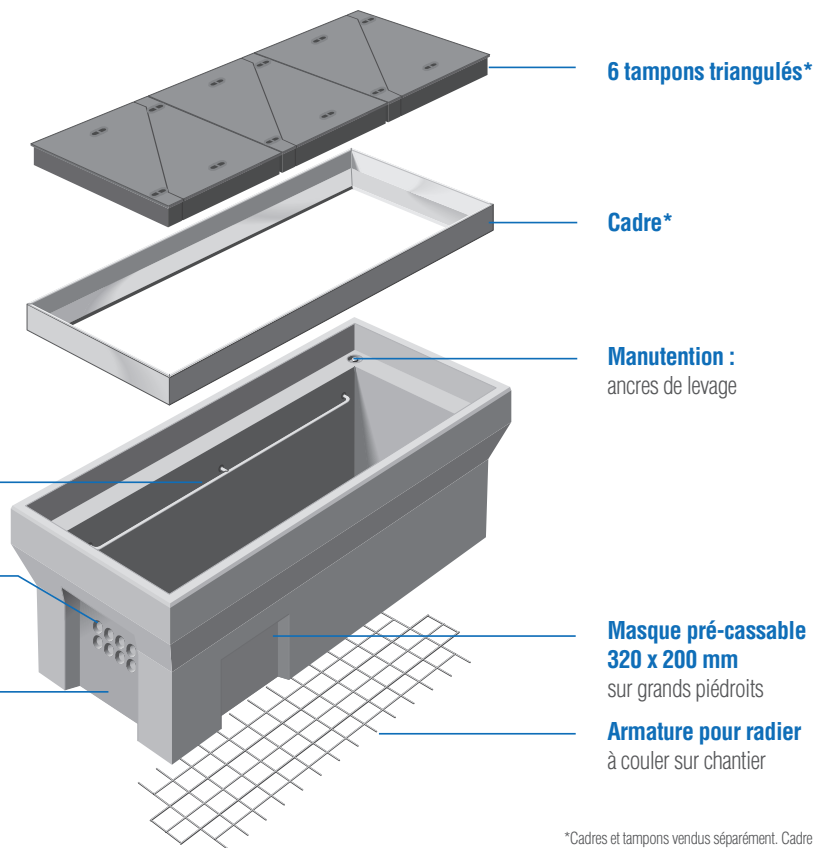

*Cadres et tampons vendus séparément. Cadre scellé en option.

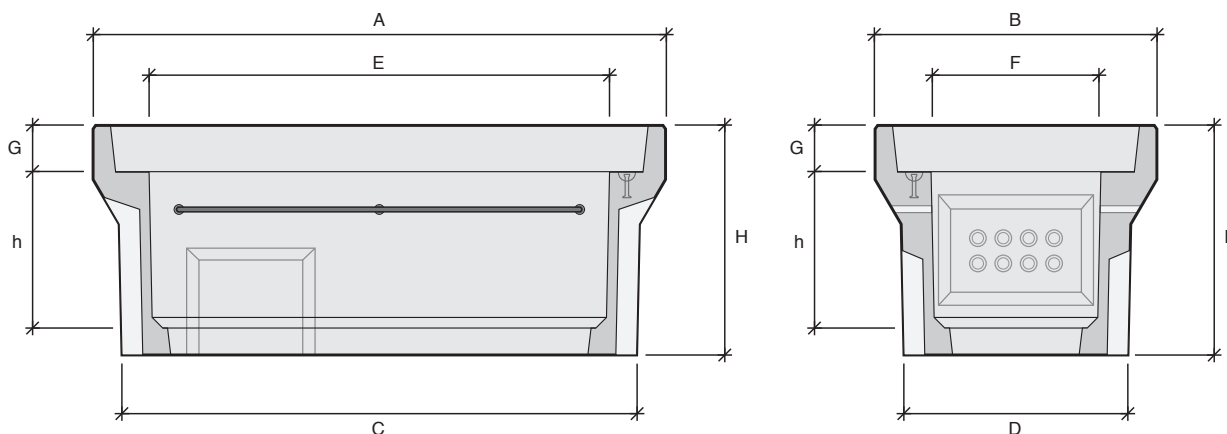

Type L

- L1C
- L1CR
- L2C
- L2CR
- L3C
- L3CR**
- L5C

Type J

- J2C

Type K

- K1C
- K1CR
- K2C
- K2CR
- K3C
- K3CR

Type M

- M1C
- M1CR
- M3C
- M3CR

Type P

- P1C
- P1CR
- P2C
- P2CR

MISE EN
OEUVRE
CCTP

TÉLÉCOMMUNICATIONS
CHAMBRES
SOUS CHAUSSÉE

Désignation	Référence	Usines	A Longueur (mm)	B Largeur (mm)	C Longueur radier (mm)	D Largeur radier (mm)	E Longueur intérieure (mm)	F Largeur intérieure (mm)	H Hauteur totale (mm)	h Hauteur utile (mm)	G Hauteur feuilure (mm)	Poids (kg)	Manutention
L3CR	110034	EB	1715	855	1540	690	1380	520	685	460	140	630	2 ancres de 1,3T